

SATURN - BOXER

MOTORIDUTTORI PER CANCELLI SCORREVOLI
MOTOR REDUCERS FOR SLIDING GATES
MOTEURS POUR PORTAILS COULISSANTS



SEA S.p.A.

Zona Industriale Sant'Atto - 64100 - Teramo - ITALY

Telephone: + 39 0 861 588341

www.seateam.com

1
GENERAL FEATURES

SATURN and **BOXER** are gearmotors designed for the automation of sliding gates. Operators are available in **version with grease** lubrication or **in oil bath version**.

Their **IRREVERSIBILITY** allows a perfect and safe closing of the gate avoiding the installation of the electric lock.

The **RELEASE SYSTEM** - placed on the front part of the external box - allows the manual opening and closing in the event of a power failure. The operators are also equipped with **ELECTRONIC ANTI-CRUSHING FUNCTION**

which guarantees the control of the gate thrust. Moreover, the **ELECTRONIC INVERSION SYSTEM** through **ENCODER (OPTIONAL JUST FOR 230V)**, makes **SATURN** and **BOXER** safe and reliable operators, as required by the Safety Regulations in force in many Countries

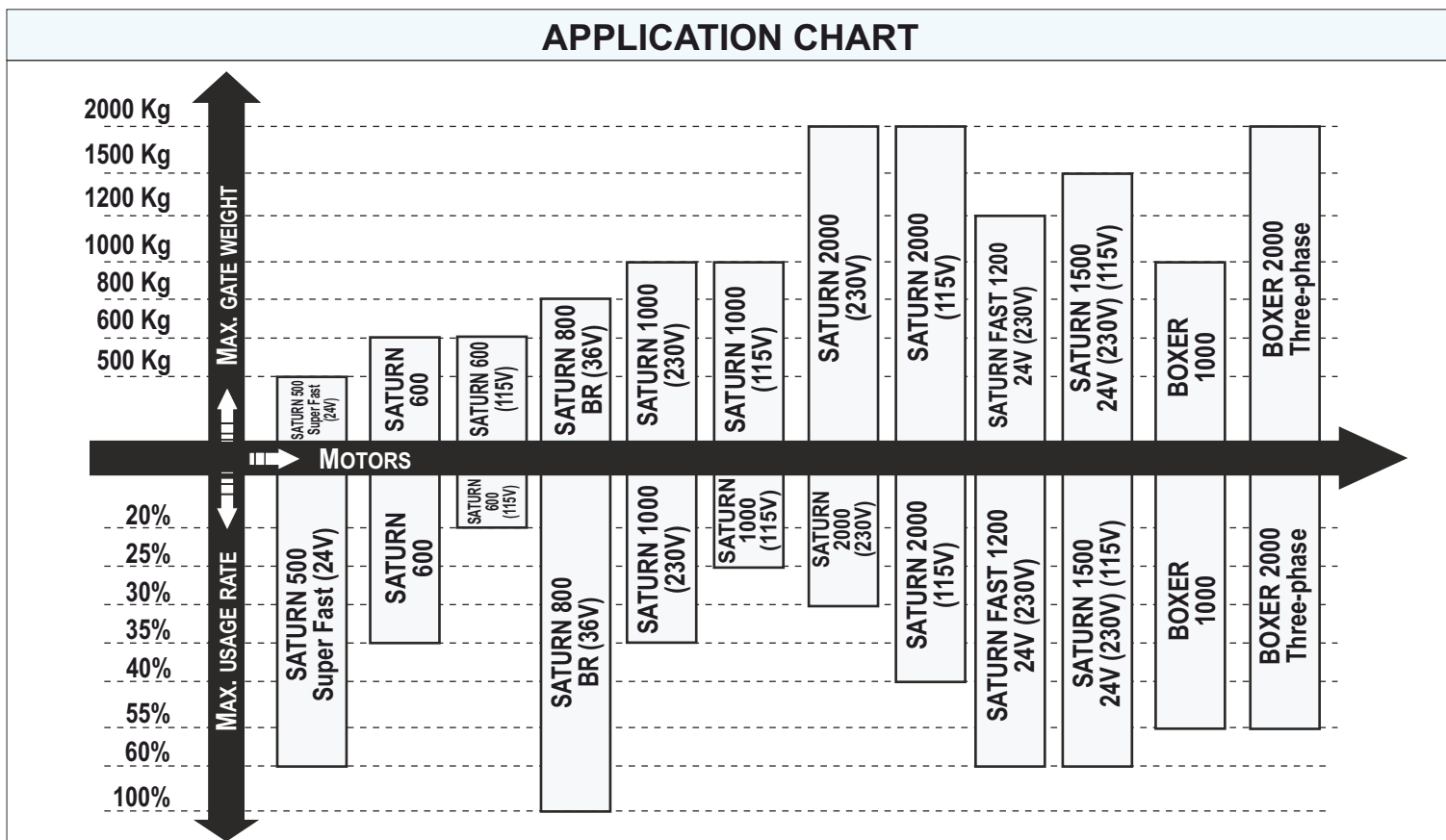
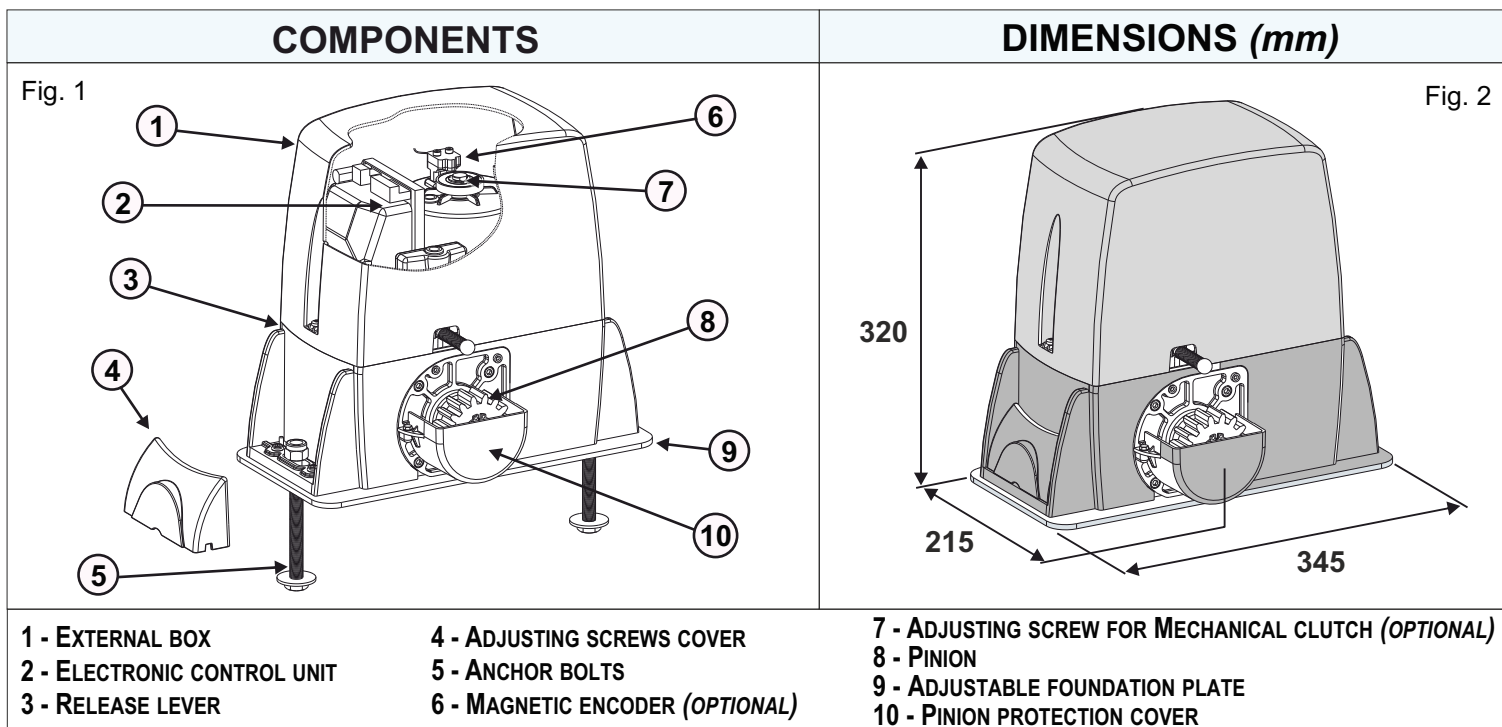

2
TECHNICAL DATA CHARTS

TECHNICAL DATA	SATURN 600 - 1000 - 2000 (230V)			SATURN 600 - 1000 - 2000 (115V)		
	SATURN 600	SATURN 1000	SATURN 2000	SATURN 600	SATURN 1000	SATURN 2000
Power Supply	230V~ ± 5% - 50/60 Hz			115V~ ± 5% - 50/60 Hz		
Motor power	320W	350W	600W	400W	700W	
Absorbed current	1,5 A	1,7 A	1,8 A	3,2 A	5,0 A	
Starting capacitor	16 µF	20 µF	25 µF	50 µF	70 µF	
Usage rate *	55%			20%	25%	40%
Operating temperature	-20°C ↯ +55°C ↯			-20°C ↯ +55°C ↯		
Thermal protection	150°C			150°C		
Operator weight	12,5 Kg	13 Kg	14,5 Kg	12 Kg	13 Kg	14,5 Kg
Anti-crushing	Electronic			Electronic		
Protection class	IP55			IP55		
Z16 (Z20) pinion speed	0,15 (0,18) m/s			0,15 (0,18) m/s		
Maximum torque	30 Nm	55 Nm	70 Nm	50 Nm	55 Nm	70 Nm
Gate max. weight	600 Kg	1000 Kg	2000 Kg	600 Kg	1000 Kg	2000 Kg
Gate max. length	6 m	10 m		6 m	10 m	
Limit switch	Inductive or Mechanical or Magnetic			Inductive or Mechanical		

TECHNICAL DATA	SATURN 800 BR 36V BRUSHLESS	SATURN 500 SUPER FAST 24V (230V)	SATURN 1200 FAST 24V (230V)	SATURN 1500 24V (230V)	SATURN 1500 24V (115V)
Power Supply	230V~ ± 5% - 50/60 Hz				115V~ ± 5% - 50/60 Hz
Motor	36V \equiv	24V \equiv			
Motor Power	330 W	100W			
Usage rate *	100%	60%			
Operating temperature	-20°C ↯ +55°C ↯				
Operator weight	14 Kg	14,3 Kg			
Anti-crushing	Electronic				
Protection class	Ip55				
Pinion speed	0,28 m/s Max (Z16)	0,40 m/s Max (Z20)	0,32 m/s Max (Z16)	0,25 m/s Max (Z13)	
Maximum torque	45 Nm	45 Nm	60 Nm	65 Nm	
Gate max. weight	800 Kg	500 Kg	1200 Kg	1500 Kg	
Gate max. length	10 m				
Limit switch	Inductive or Mechanical				

TECHNICAL DATA	BOXER 1000	BOXER 2000	BOXER 2000 Three-phase	NOTES	
Power Supply	230V~ ± 5% - 50/60 Hz		230V/380V (±5%) 50/60Hz	* The indicated usage rate is valid only for the first operating hour and at a 20°C room temperature	
Motor power	350W	700W	400W		
Absorbed current	1,7 A	1,8 A	1,0 A		
Starting capacitor	20 µF	25µF	-	In the versions SATURN and BOXER with INVERTER, the max speed allowed by the different pinions is shown in the following table:	
Usage rate *	70%		50%		
Operating temperature	-20°C ↯ +55°C ↯				
Thermal protection	150°C		-	SATURN 1000/2000 INVERTER BOXER 1000/2000 INVERTER	
Operator weight	14 Kg	15 Kg			
Anti-crushing	Electronic/Mechanical				
Protection class	IP55			PINION Z13 Max. 0,21 m/s PINION Z16 Max. 0,266 m/s PINION Z20 Max. 0,33 m/s	
Z16 (Z20) pinion speed	0,15 (0,18) m/s				
Maximum torque	55 Nm	70 Nm			
Gate max. weight	1000 Kg	2000 Kg			
Gate max. length	10 m				
Mechanical clutch	Optional (<i>on prepared models</i>)				
Limit switch	Inductive or Mechanical				

3
GATE ARRANGEMENT

Before the installation, check that all gate parts (fixed and mobile) have a strong and non-deformable structure; also make the following checks:

- 3.1. The gate must be rigid and compact;
- 3.2. The lower gate slideway must be perfectly straight, horizontal and without any obstacles which could obstruct the gate sliding;
- 3.3. The lower sliding wheels must be equipped with greasable or watertightened bearings;
- 3.4. The upper slideway must be perfectly straight and placed so that the gate could be in vertical position;
- 3.5. *The mechanical stops of the gate must always be installed in order to avoid any possible derailment*

START UP THE OPERATOR ONLY AFTER THE INSTALLATION PROCEDURE HAS BEEN COMPLETED

4
INSTALLATION OF THE FOUNDATION PLATE

To install the foundation plate it is necessary to:

4.1. Prepare a concrete basement according to the dimensions shown in Fig. 3; The foundation plate and the anchor bolts must be concreted inside the basement

IF ALLOWED BY THE GATE STRUCTURE, IT IS RECOMMENDED TO LIFT THE FOUNDATION PLATE OF ABOUT 50mm FROM THE GROUND, IN ORDER TO AVOID EVENTUAL WATER STAGNATION.

4.2. Before cementing the plate insert a flexible plastic pipe of at least **30 mm** in diameter into the special hole of the plate

4.3. Before concreting the plate, make sure that it is perfectly leveled and that the distance of **58 - 67 mm** as shown in Fig. 4 is respected

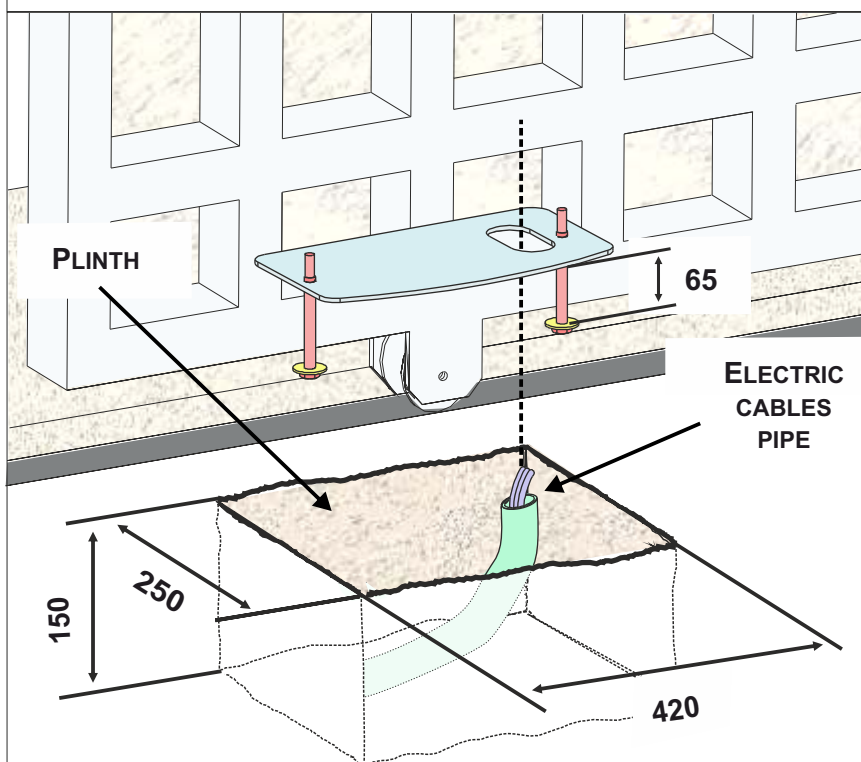

Fig. 3

DIMENSIONS IN mm

MINIMUM Q DIMENSION	
Z16	108 mm
Z20	116 mm

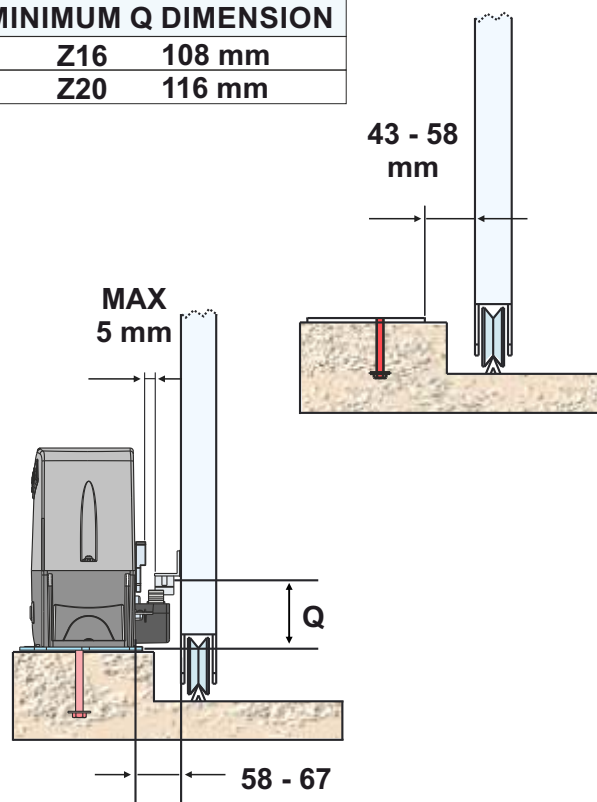



Fig. 4

5 ELECTRIC CABLES PASSAGE

OPERATORS are equipped with two separate holes for the passage of electric cables.

 Do not pass the 230V~ voltage cables through the same holes as the 24V very low safety voltage cables

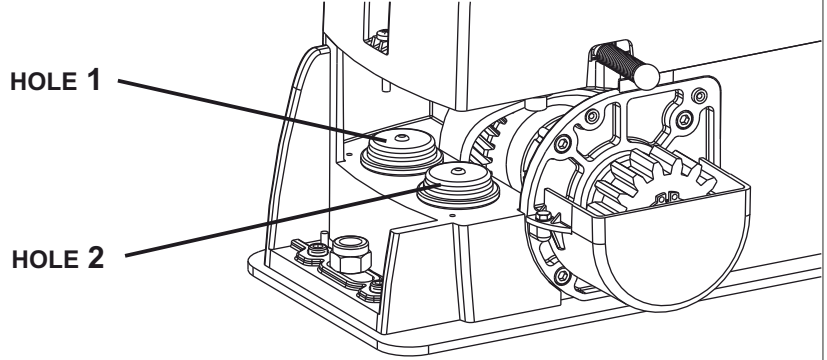

Fig. 5

6 INSTALLATION OF THE OPERATOR

6.1. Insert the 4 grub screws into the holes inside the lower casing, in order to adjust the height of the gearmotor to the plate; fix the grub screws with the nuts - Fig. 6

6.2. Fix the gearmotor to the foundation plate using the 2 nuts provided, adjusting its lateral position - Fig. 7 - to comply with the dimensions indicated in Fig. 4

 **MAKE SURE THE 4 GRUB SCREWS ARE FIRMLY FASTEN TO THE FOUNDATION PLATE!**

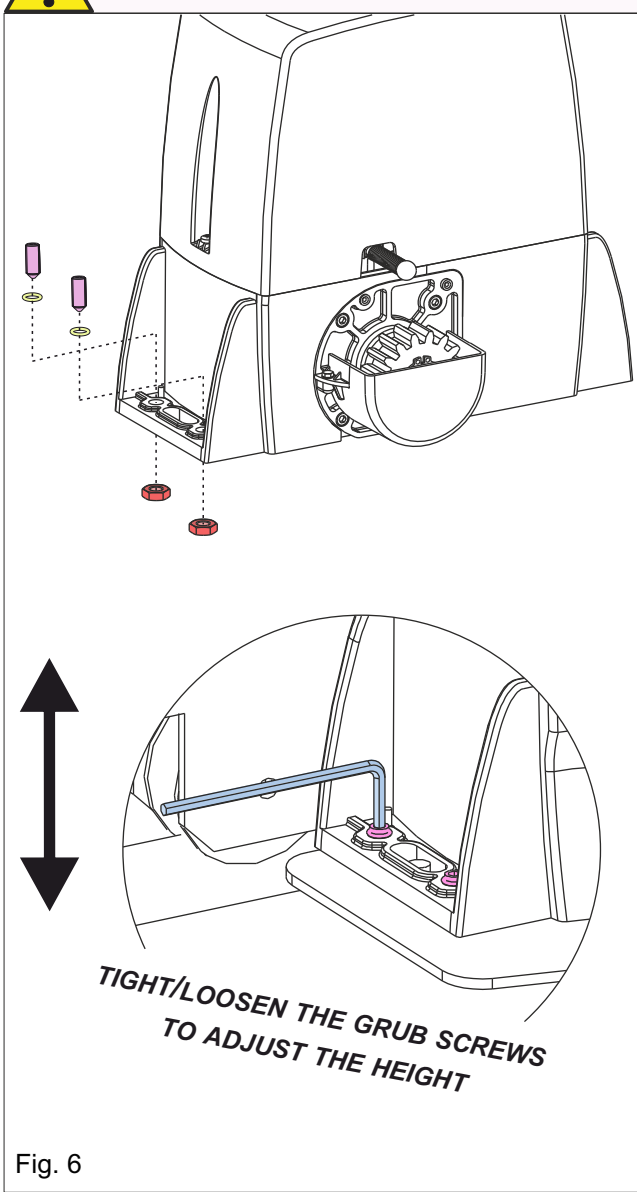

Fig. 6

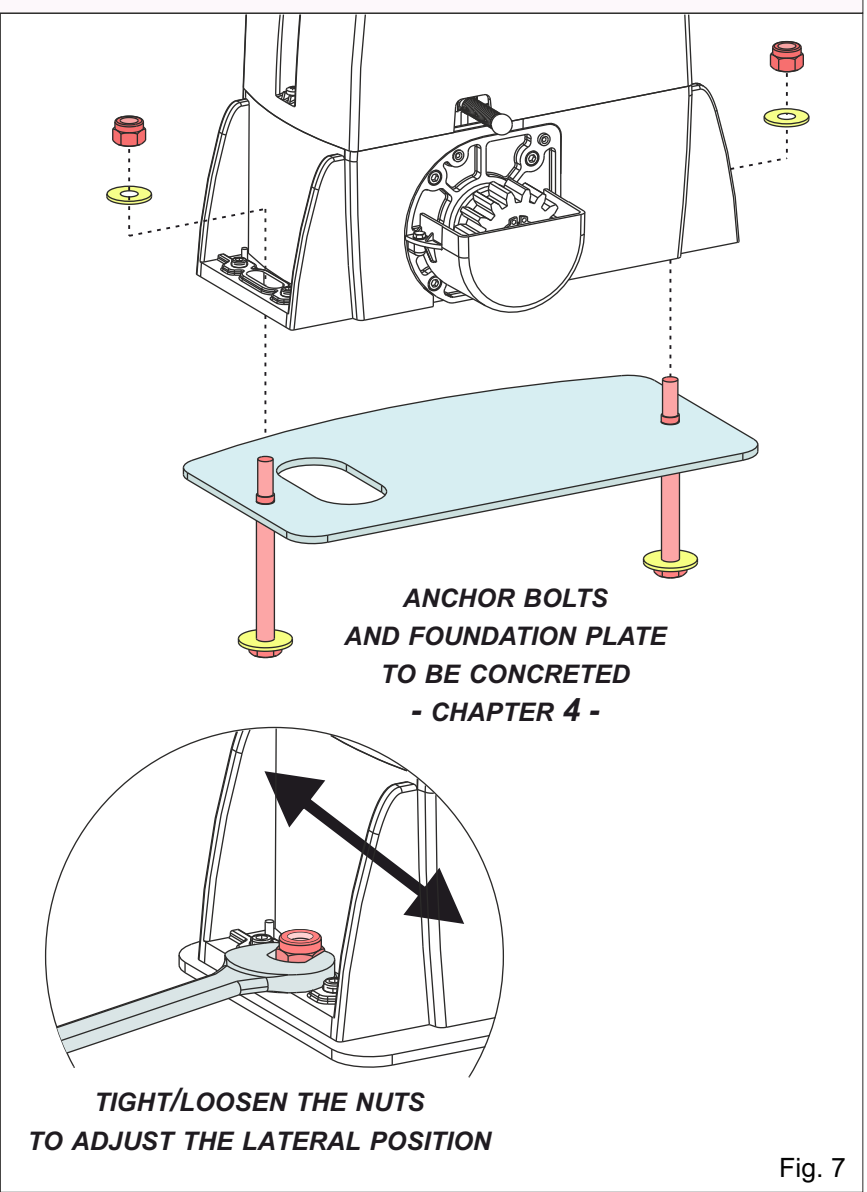

Fig. 7

7

GEAR RACK MOUNTING

- 7.1. Release the operator and open the gate completely;
- 7.2. Fix on each gear rack element the support pawls with the appropriate lock screws, making sure to put them in the upper part of the hole - Fig. 8;
- 7.3. Lean the gear rack element on the toothed pinion of the operator in parallel to the ground slideway of the gate, as shown in Fig. 9 and electrically weld the central pawl **B** to the gate structure - Fig. 10. Manually move the gate until pawl **C** is placed in front of the pinion and fix it through electric welding. Repeat the same procedure for pawl **A** after having placed it in front of the pinion;
- 7.4. Make sure that all the gear rack elements are perfectly aligned and correctly placed (**the teeth must be in phase**). It is suggested to oppose an element to two aligned elements as shown in Fig. 11;
- 7.5. Repeat the above described operation for all the remaining gear rack elements which have to be installed;
- 7.6. To avoid that the gate weights down the pinion - Fig.12 - lift up the whole rack of about **1,5 mm**. **CAUTION! KEEP A GAP OF ABOUT 0,5 mm BETWEEN THE PINION TOOTH AND THE GEAR RACK TOOTH;**
- 7.7. Make sure that the gear rack works at the midpoint of the pinion along all the rack elements, if necessary, adjust the length of the spacers

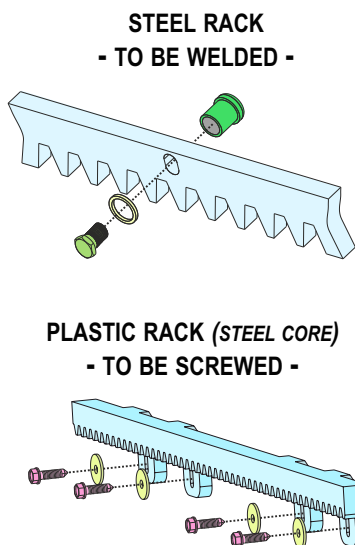

Fig. 8

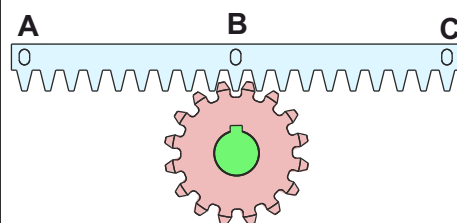

Fig. 9

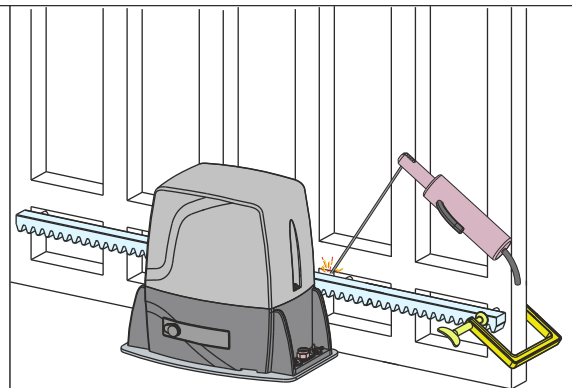

Fig. 10

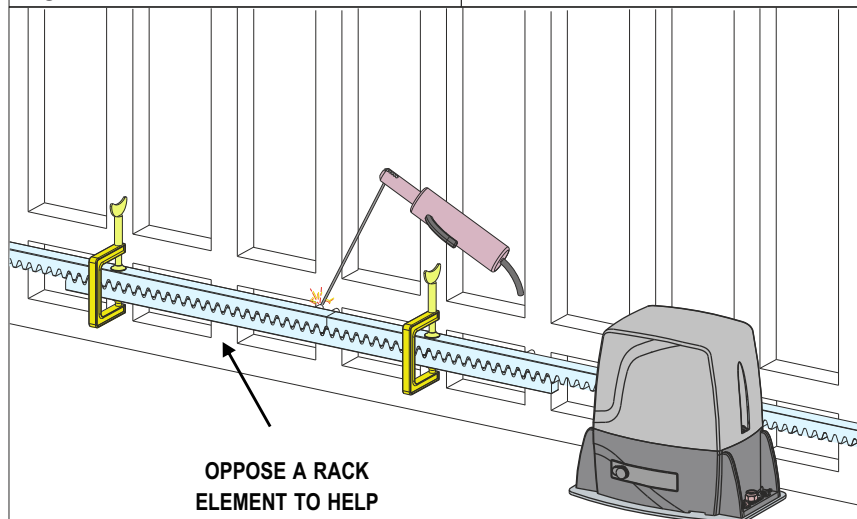

Fig. 11

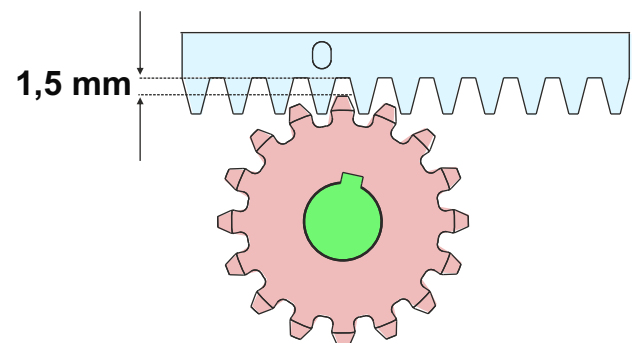

Fig. 12

8 LIMIT SWITCH INSTALLATION AND ADJUSTMENT

8.1. IN OPENING

- Manually move the gate wide open
- **MECHANICAL STOP:** place the plate - Fig. 13 - on the rack according to the desired gate stop position; fix the plate on the rack using the screws
- **INDUCTIVE LIMIT SWITCH:** place the plate - Fig. 14 - on the rack according to the desired gate stop position; fix the plate on the rack using the screws. Bring the inductive limit switch **opening** plate (indicated by an arrow on the limit switch) in correspondence with point «X» of the plate on the rack (**50 mm from the folded side of the plate** - Fig. 15)

8.2. IN CLOSING

- Manually close the gate
- **MECHANICAL STOP:** place the plate - Fig. 13 - on the rack according to the desired gate stop position; fix the plate on the rack using the screws
- **INDUCTIVE LIMIT SWITCH:** place the plate - Fig. 14 - on the rack according to the desired gate stop position; fix the plate on the rack using the screws. Bring the inductive limit switch **closing** plate (indicated by an arrow on the limit switch) in correspondence with point «X» of the plate on the rack (**50 mm from the folded side of the plate** - Fig. 15)

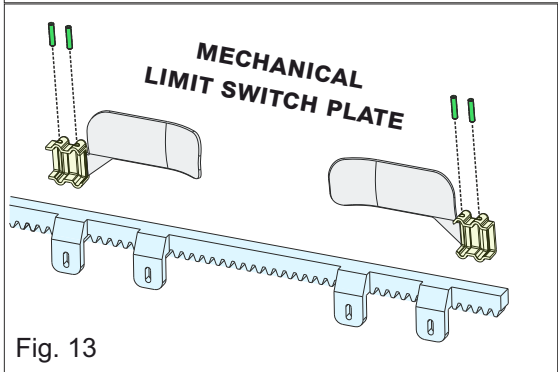

Fig. 13

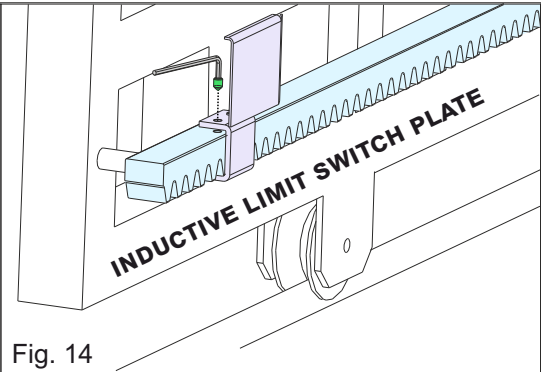

Fig. 14

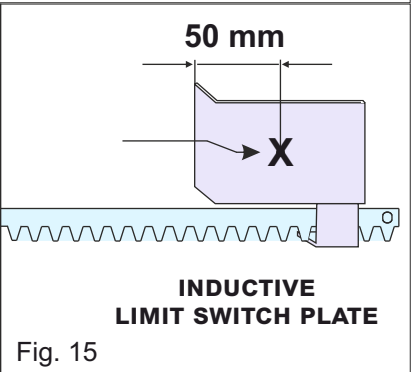

Fig. 15

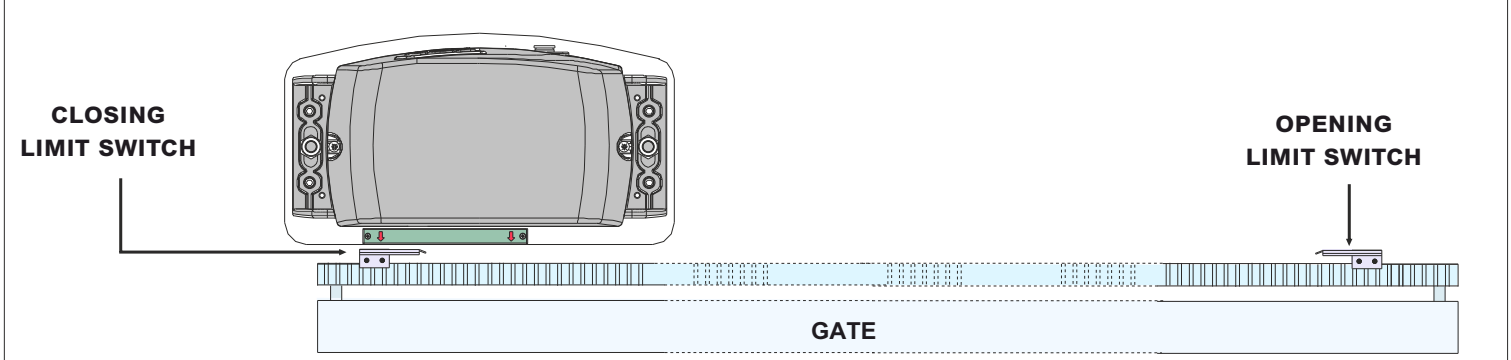

Fig. 16

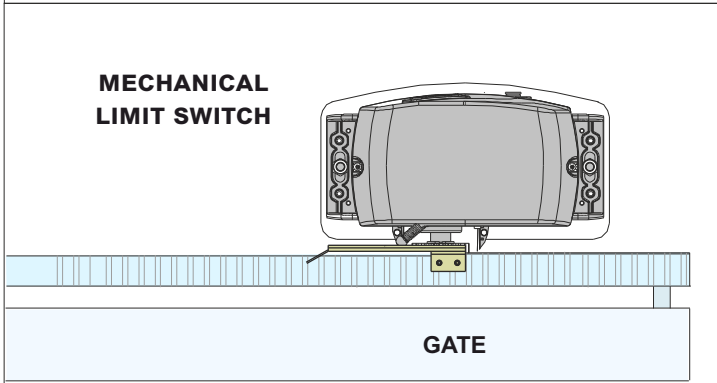

Fig. 17

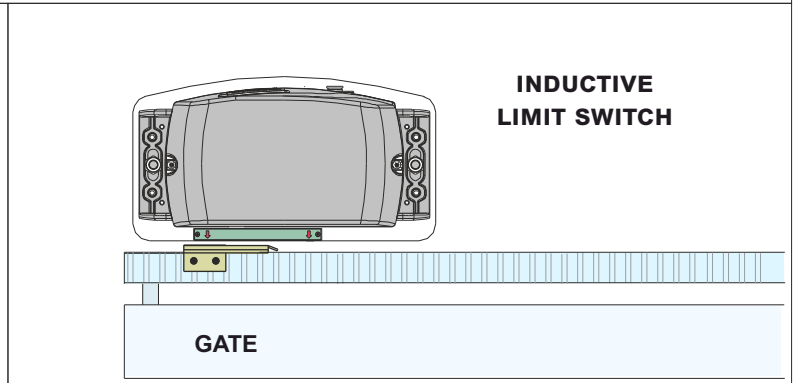

Fig. 18

➔ AFTER STARTING UP THE OPERATOR, IT MAY BE NECESSARY TO MANUALLY ADJUST THE PLATES, BOTH IN OPENING AND CLOSING. ANY FURTHER ADJUSTMENTS ALSO CAN BE MADE ON THE ELECTRONIC CONTROL UNIT!

9 MAGNETIC LIMIT SWITCH ADJUSTMENT - MODELS WITH MAGNETIC LIMIT SWITCH

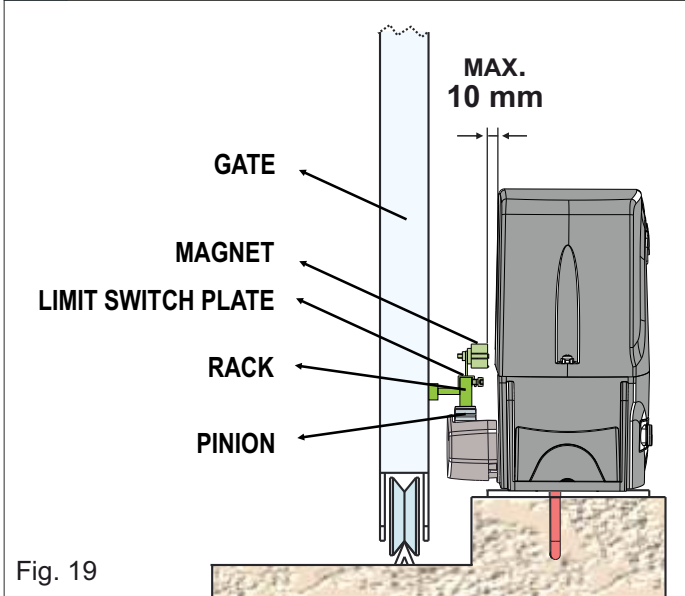

Fig. 19

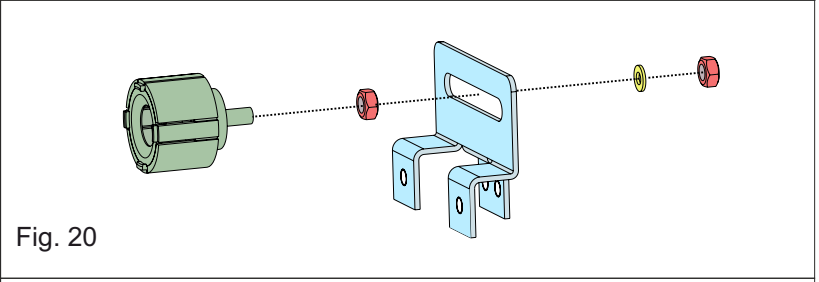

Fig. 20

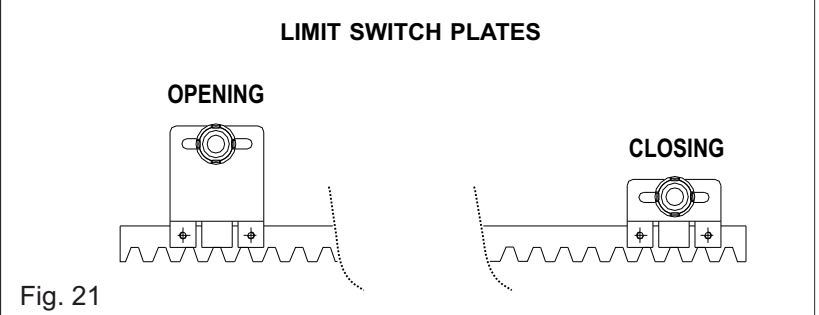

Fig. 21

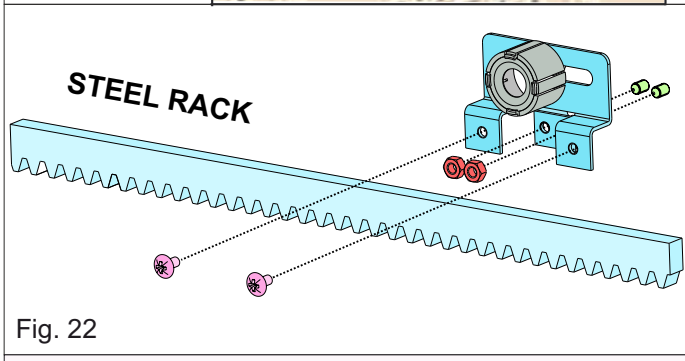

Fig. 22

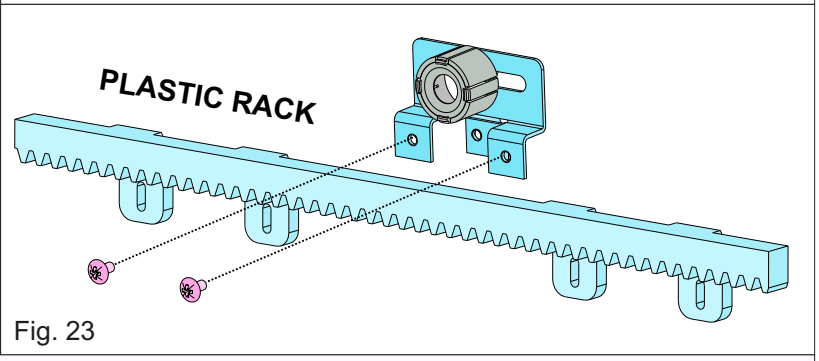

Fig. 23

➔ **ONCE INSTALLATION IS COMPLETE, CHECK THE LIMIT SWITCHES CORRECT READING ON THE ELECTRONIC CONTROL UNIT**

10 CLUTCH ADJUSTMENT - JUST FOR MODELS WITH OPTIONAL CLUTCH

- 10.1.** Switch off the electric power supply
- 10.2.** To adjust the clutch, act on the grub screw «A» Fig. 24 - as follows:
- **CLOCKWISE DIRECTION** = less clutch sensitivity - more thrust force
 - **COUNTER-CLOCKWISE DIRECTION** = more clutch sensitivity - less thrust force

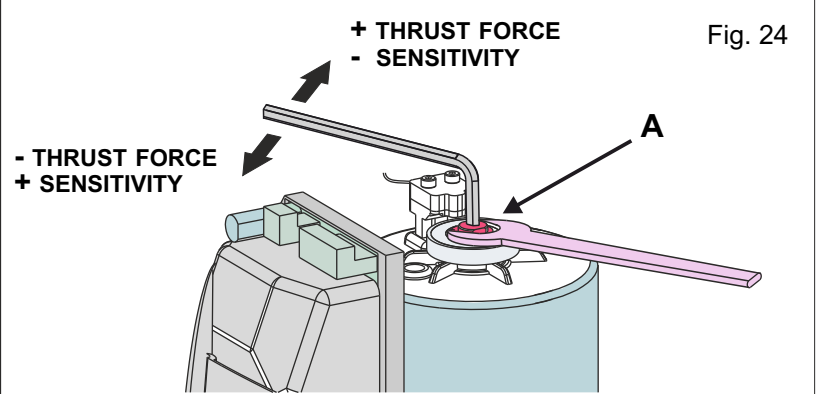

Fig. 24

11 SCREW-COVER MOUNTING

- 11.1.** At the end of the mechanical installation and after carrying on all the required adjustments, mount the two screw-covers on the operator, as shown in Fig. 25

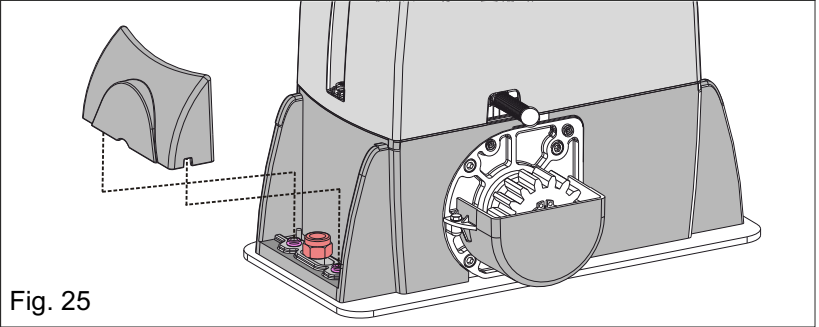

Fig. 25

12 GROUNDING

12.1. Before connecting the operator, ensure that it is earthed, as shown in Fig. 26 or Fig. 27, depending on the model in use.

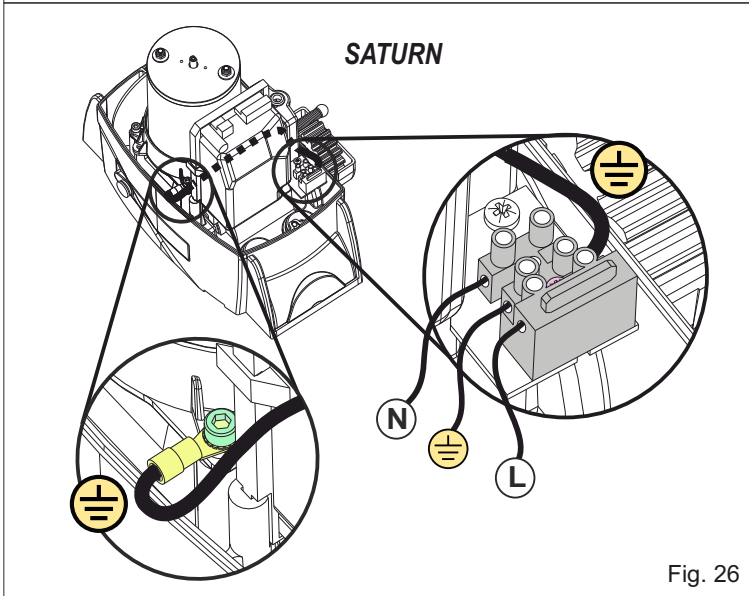

Fig. 26

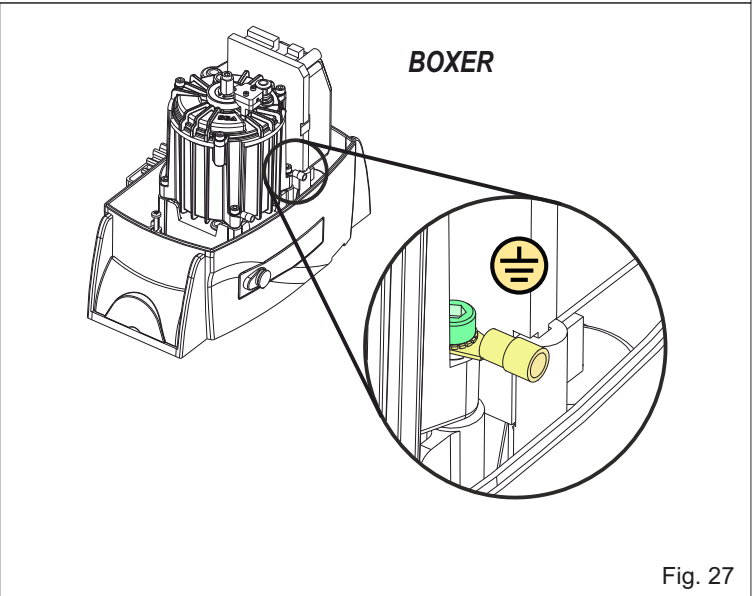
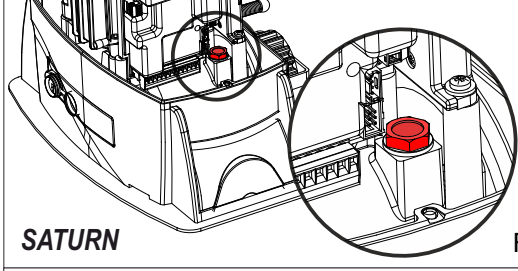

Fig. 27

13 BREATHER CAP REPLACEMENT (OIL LEVEL CAP*)

13.1. BEFORE STARTING UP THE OPERATOR, REMOVE THE RED TRANSPORT CAP (ON «OIL» VERSIONS ONLY) and replace it with the black cap supplied which are equipped with an airhole



SATURN

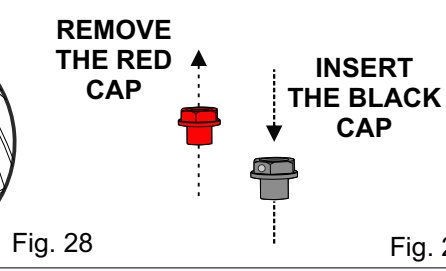
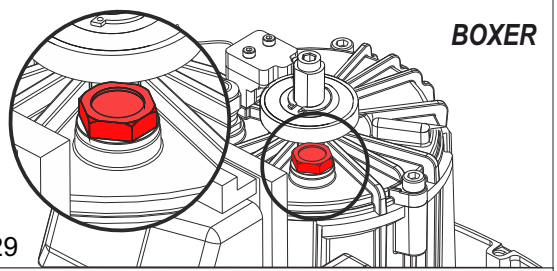

Fig. 28



BOXER

Fig. 29

* FOR «OIL» OIL-BATH MODELS: TO TOP UP THE ENGINE OIL, LIFT THE BLACK CAP, TOP UP THE OIL AND CLOSE IT AGAIN.

14 STANDARD INSTALLATION WIRING

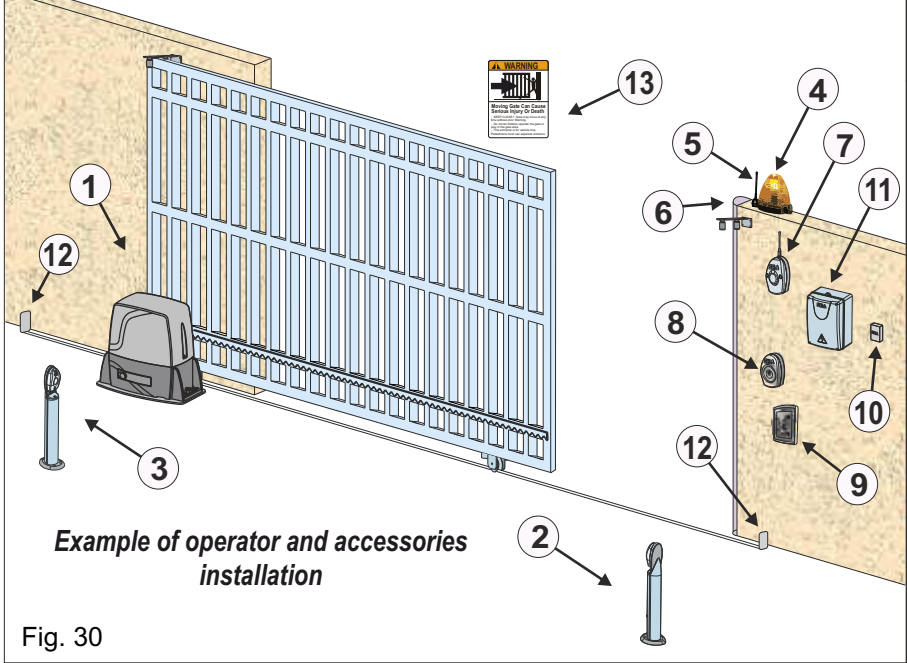

Fig. 30

RECOMMENDED CABLES NUMBER AND SECTION FOR WIRINGS ON CONTROL UNIT

1) OPERATOR	4 x 1,5
2) PHOTOCELL TX	2 x 0,5
3) PHOTOCELL RX	4 x 0,5
4) FLASHING LAMP	2 x 0,5
5) ANTENNA	1 x RG58
6) SAFETY EDGE	2 x 0,5 *
7) EXTERNAL RECEIVER	4 x 0,5
8) KEY-BUTTON	4 x 0,5
9) KEYPAD	4 x 0,5
10) DIFFERENTIAL 16A/30mA	3 x 1,5 **
11) CONTROL UNIT BOX	
12) END-OF-STROKE MECHANICAL STOPS	
13) WARNING SIGNS	

* In case of powered safety edge: 4 x 0,5
 ** Increase the cable section in case of high distance from the control unit

PART FOR BOTH INSTALLER AND END-USER

ALL THE UNLOCKING AND LOCKING OPERATIONS AND ALL PERIODIC MAINTENANCE OPERATIONS MUST BE CARRIED OUT IN ABSENCE OF POWER SUPPLY!

15 RELEASE SYSTEM
15.1. TO RELEASE THE OPERATOR

- Open the lock cover, insert the key and rotate 90° clockwise - Fig. 31
- Pull the release lever until it stops, about 90° - Fig. 32

when pulling the release lever, the control unit receives a safety stop impulse thanks to a micro-switch inside the operator (anyway, it is highly recommended to switch OFF the power supply before)

15.2. TO LOCK THE OPERATOR

- Push the release lever to the complete closing
- Rotate the key counter-clockwise and extract it
- Close the protective lock cover

Once the lock has been restored the electronic control unit reactivates - if the power supply was ON!

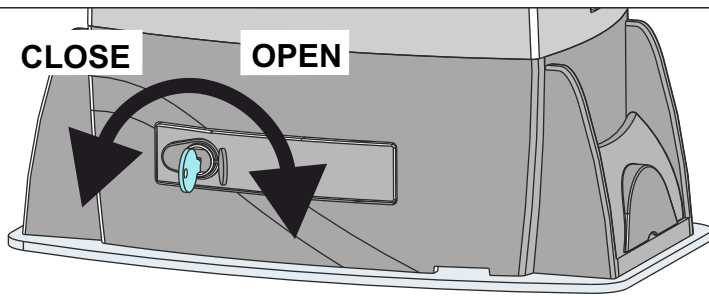

Fig. 31

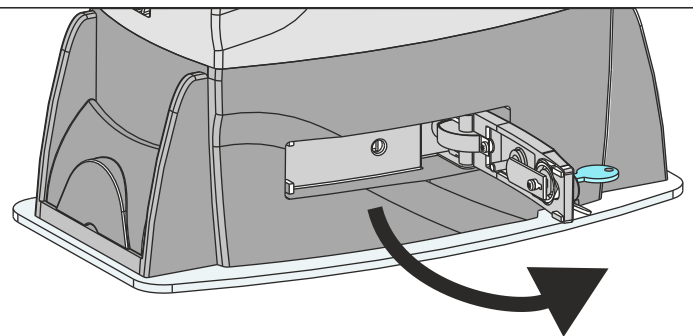

Fig. 32

16 PERIODIC MAINTENANCE - FOR INSTALLERS ONLY!

CHECK THE OIL LEVEL	ANNUAL
CHANGE THE OIL	4 YEARS
CHECK THE CORRECT OPERATION OF THE RELEASE SYSTEM	ANNUAL
CHECK THE CORRECT OPERATION OF THE CLUTCH (JUST FOR MODELS WITH CLUTCH)	ANNUAL
CHECK THE DISTANCE BETWEEN PINION AND GEAR RACK (1.5 mm)	ANNUAL
CHECK THE CONDITION OF THE PINION AND THE GEAR RACK (IF OVERUSED OR DAMAGED)	ANNUAL
CHECK ALL THE FASTENING SCREWS	ANNUAL
CHECK THE CONDITION OF THE ELECTRIC CABLES	ANNUAL
CHECK THE CORRECT OPERATION OF THE LIMIT SWITCHES IN OPENING AND CLOSING; ALSO CHECK THE CONDITION OF THE STOP PLATES	ANNUAL



**ALL OPERATIONS MUST BE CARRIED OUT EXCLUSIVELY BY AN AUTHORIZED INSTALLER
ALL OPERATIONS MUST BE CARRIED OUT IN ABSENCE OF POWER SUPPLY**

PART FOR BOTH INSTALLER AND END-USER

GENERAL NOTICE

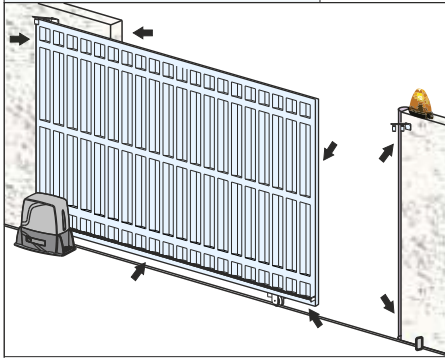

RISK EXAMINATION: The points pointed by arrows are potentially dangerous. The installer must take a thorough risk examination to prevent crushing, conveying, cutting, grappling, trapping so as to guarantee a safe installation for people, things and animals (Re. Laws in force in the Country where installation has been made). As for misunderstandings that may arise refer to your area distributor or call our help desk. These instructions are part of the device and must be kept in a well-known place. The installer shall follow the provided instructions thoroughly. SEA products must only be used to automate doors, gates and wings. Any initiative taken without SEA explicit authorization will preserve the manufacturer from whatsoever responsibility. The installer shall provide warning notices on not assessable further risks. SEA in its relentless aim to improve the products, is allowed to make whatsoever adjustment

without giving notice. This doesn't oblige SEA to upgrade the past production. SEA cannot be deemed responsible for any damage or accident caused by product breaking, being damages or accidents due to a failure to comply with the instructions herein. The guarantee will be void and the manufacturer responsibility will be nullified if SEA original spare parts are not being used. The electrical installation shall be carried out by a professional technician who will release documentation as requested by the Laws in force. Packaging materials such as plastic bags, foam polystyrene, nails etc. must be kept out of children's reach as dangers may arise.

INITIAL TEST AND STARTING OF THE AUTOMATION: After having completed the necessary operations for a correct installation of the product and after having evaluated all the risks which could arise in any installation, **it is necessary to test the automation to guarantee the maximum safety and to guarantee that the Laws in force are fully respected.** The first Start must be executed according to the rule **EN 12445** which establishes the methods of tests for checking the gate automation respecting the limits established by the rule **EN 12453**

SAFETY PRECAUTIONS: All electrical works should comply with the current regulations. A 16A/0,030 differential switch must be used. Separate the source cables (operators, power supply) and command cables (photocells, push-buttons, etc). Be sure the entire system is properly grounded. Always run cables in separate ducts to prevent interferences

INTENDED USE: The operator has been designed to be used for the automation of sliding gates only

SPARE PARTS: Send request for spare parts to: **SEA S.p.A. - Teramo - ITALY - www.seateam.com**

SAFETY AND ENVIRONMENTAL COMPATIBILITY: Don't waste product packing materials and/or circuits

STORAGE: T = -30°C/+60°C ; Humidity = min. 5% / max. 90% (without condensation); Materials must be properly packaged, handled with care and with appropriate vehicles

WARRANTY LIMITS - see the sales conditions

MAINTENANCE AND DECOMMISSION: must only be carried out by specialized and authorized personnel

THE MANUFACTURER CAN NOT BE DEEMED RESPONSIBLE FOR ANY DAMAGE OR INJURY CAUSED BY IMPROPER USE OF THIS PRODUCT

SEA S.p.A. reserves the right to make any required modification or change to the products and/or to this manual without any advanced notice obligation.

1. Read carefully these instructions before beginning to install the product. Store these instructions for future reference
2. Don't waste product packaging materials and/or circuits
3. This product was designed and built strictly for the use indicated in this documentation. Any other use, not expressly indicated here, could compromise the good condition/operation of the product and/or be a source of danger. SEAS.p.A. declines all liability caused by improper use or different use in respect to the intended one.
4. The mechanical parts must comply with Directives: Machine Regulation 2006/42/CE and following adjustments, Low Tension (2006/95/CE), Electromagnetic Consistency (2004/108/CE); Installation must respect Directives: EN12453 and EN12445.
5. Do not install the equipment in an explosive atmosphere.
6. SEA is not responsible for failure to observe Good Techniques in the construction of the locking elements to motorize or for any deformation that may occur during use
7. Before attempting any job on the system, cut out electrical power and disconnect the batteries. Be sure that the grounding system is perfectly constructed and connect to it the metal parts of the gate
8. Use of the indicator-light is recommended for every system, as well as a warning sign well-fixed to the frame structure.
9. SEA declines all liability concerning the automated system safety and efficiency, if components used are not produced by SEA
10. For maintenance, strictly use original parts by SEA.
11. Do not modify in any way the components of the automated system.
12. The installer shall supply all information concerning the system manual functioning in case of emergency and shall hand over to the user the warnings handbook supplied with the product.
13. Do not allow children or adults to stay near the product while it is operating. The application cannot be used by children, by people with reduced physical, mental or sensorial capacity or by people without experience or necessary training. Keep remote controls or other pulse generators away from children, to prevent involuntary activation of the system.
14. Transit through the leaves is allowed only when the gate is fully open.
15. The User must not attempt to repair or to take direct action on the system and must solely contact qualified SEA personnel or SEA service centers. The User can apply only the manual function of emergency.
16. The power cables maximum length between the central engine and motors should not be greater than 10 m. Use cables with 2,5 mm² section. Use double insulation cable (cable sheath) to the immediate vicinity of the terminals, in particular for the 230V cable. Keep an adequate distance (at least 2.5 mm in air), between the conductors in low voltage (230V) and the conductors in safety low voltage (SELV) or use an appropriate sheath that provides extra insulation having a thickness of 1 mm



SEA®



Automatic Gate Openers

International registered trademark n. 804888

SEA S.p.A.

Zona Industriale Sant'Atto - 64100 - Teramo - ITALY

Tel. +39 0 861 588341 r.a. Fax +39 0 861 588344

www.seateam.com